

MyoLoop for cardiovascular research

MyoLoop is a device that simulates the synchronised mechanical and electrical events that occur in the heart inside the body (*in vivo*), on an *in vitro* heart model known as myocardial slice (MS). The system is self-contained, and designed for chronic experiments, that is culture of myocardial slices. MyoLoop can simulate pathological (e.g. hypertension), to study their progression, and the effects of therapeutic interventions on them.

Proposed use

- Preclinical drug testing
- Modelling cardiac diseases *in vitro*
- Studying the effect of interventions on the heart *in vitro*
- Engineered heart tissue maturation

Problem addressed

There are no devices that simulate the *in vivo* cardiac cycle at the *in vitro* level

MyoLoop runs a custom software that simulates the cardiac cycle allowing myocardial slices (an *in vitro* cardiac model) to beat as they would *in vivo*.

A simple graphical user interface offers control of the cardiac cycle parameters, allowing researchers to study of a spectrum of physiological or pathological conditions.

MyoLoop is a standalone device. Using it is as simple as placing it on a lab bench.

Technology overview

MyoLoop is the first commercially available device that chronically culture heart tissue, under the same mechanical and electrical events that occur inside the body, by recreating the cardiac cycle.

- Simulation of cardiac cycle. Myocardial slices perform work loops as they would *in vivo*. The cardiac cycle parameters are user-selected and can be changed to simulate disease and health.
- MyoLoop is a standalone benchtop device. It is easy to use and comes configured with:
 - Temperature control (i.e. no incubator is required)
 - Culture media recirculation (no peristaltic pump is required)
 - Tissue pacing (i.e. no external stimulator required)
 - Automatic data analysis software
 - Autoclavable culture chamber
 - Compact and sturdy design

Benefits

- First device to recreate cardiac cycle *in vitro* for chronic culture experiments
- Standalone device
- For basic and translational research

Name of executive:

Dr Emily Allen-Benton

Industry Partnerships and
Commercialisation Officer, Faculty of
Medicine

e: e.allen-benton@imperial.ac.uk

Technology reference: **10482**

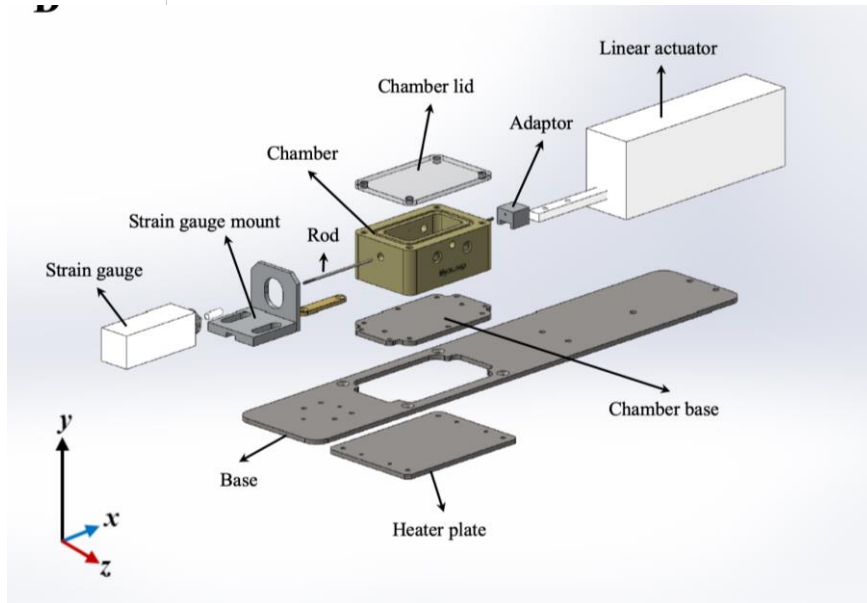

Intellectual property information

The technology is protected by a provisional patent application.

Link to published paper(s)

F. Pitoulis, R. Nunez-Toldra, Worrarpong, S. Kit-Anan, E. Dries, I. Bardi, F. Perbellini, S. Harding, P. de Tombe, C. Terracciano; Exploring Mechanical Load-Induced Cardiac Remodelling Using a Novel Organotypic Myocardial Slice Model, *Biophysical Journal*, (118) 3, Supplement 1, 2020.

Inventor information

Cesare Terracciano is Professor of Cardiac Electrophysiology, Director of the BSc Cardiovascular Sciences at Imperial College and PI of the British Heart Foundation Cardiovascular Regenerative Centre. Professor Terracciano's research on the mechanisms of myocardial regeneration following mechanical devices, stem and gene therapy, and the cellular and molecular mechanisms of arrhythmias.

Fotios Pitoulis is an MD-PhD student at Imperial College London funded by the British Heart Foundation under the MBPhD studentship scheme. The aim of his PhD is the development of a novel 3D multicellular myocardial platform for physiological, pathological, pharmacological and regenerative studies.